

# FELLER GMBH

A-2525 GUENSELSDORF, AUSTRIA - TEL.: . . 43(2256) 62 32 50 - FAX: . . 43 (2256) 62 32 57  
e-mail: sales@feller-at.com <http://www.feller-at.com>

## Description: HG/TR-SJT3x18AWG-C13/3,00M BLACK NA-cc

Rating of cord set: 10A,125Vac

### 1. PLUG: Type HG/TR (transparent)

Molded plug according to : NEMA 5-15 (HOSPITAL GRADE)  
Color of plug : transparent  
Front side marking : green dot  
Rated current and voltage : 15 A, 125 V AC  
Plugbase : thermoplastic Polyester (PBTP) GFR  
Pins : solid brass, nickel plated, crimped  
Pins dimension : grounding O.D. 4,8 mm  
line and neutral 6,20 mm x 1,40 mm  
Outer mold : PVC compound, hardness Shore A 89 +/- 3  
Approvals : UL, CSA

### 2. CORD: Type SJT3x18AWG

Flexible cord according to : UL62, CSA 22.2 No.49  
Marked : \*JF\*UL\*E41542\*SJT\*3X18AWG\*(0.82mm2)\*60C\*300V\*FT2\*CSA  
Number of cores : 3  
Conductor construction : 48 x 0,15 mm O.D. 1,25mm  
Conductor insulation : Extruded PVC, O.D. 2,80mm  
Jacket : Extruded PVC, O.D. 7,70 mm +/-0,20mm  
Temperature rating : max. +60°C  
Resistance of conductors : max. 22,37 Ω/km  
Dielectric strength : 2kVac, 1min.  
Insulation resistance : >0,010 MΩ/km  
Color of conductors : green,black,white  
Approvals : UL, CSA

### 3. CONNECTOR: Type C13

Molded connector according to : EN/IEC60320/C13,UL817,C22.2No.21  
Rated current and voltage : 10 A, 125 V AC (USA,CANADA)  
Construction : double insulation  
Contacts of the connection : self-adjusting phosphor bronze CuSn6  
Inner insulation : PPO GFR  
Outer mold : PVC compound, hardness Shore A 75-77  
Approvals : UL, CSA

Environmental conformity : EU-Directive 2002/96/EC (WEEE)  
EU-Directive 2011/65/EU  
EU-Directive 1907/2006 EG (REACH -compliant)

### TESTING

Electrical testing : 100%  
Visual inspection : 100%  
High pot test wire to wire : 3kVac for 2 sec.  
Continuity test : 25Aac to grounding / 20Aac to line and neutral  
Polarity test : yes  
Skin high pot test : 6kVac line to skin

Tolerances not indicated in the drawing: +/- 2 %  
design subject to change without prior notice

DATE of ISSUE:	April, 2015		
REV: 2	1	ORIG:	lg

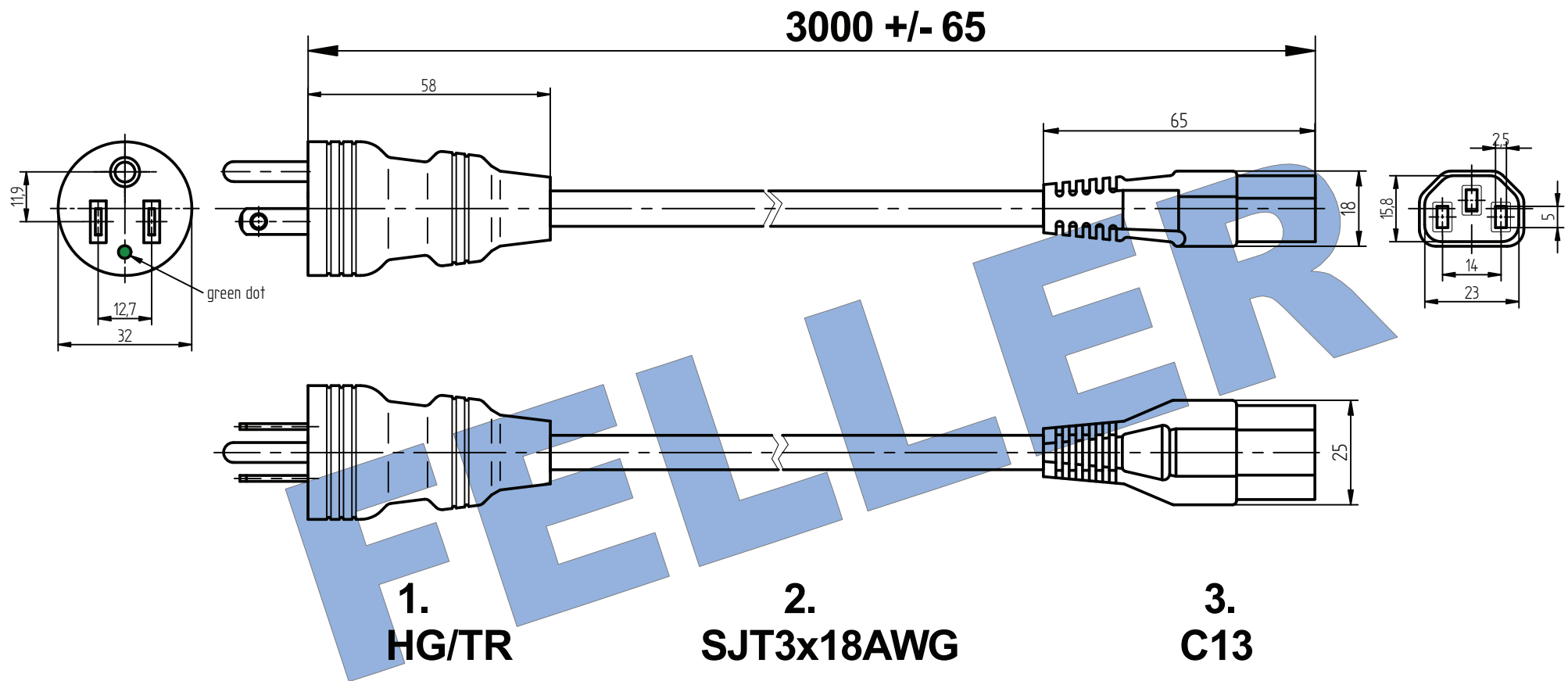

**Feller Type: HG/TR-SJT3x18AWG-C13/3,00M BLACK NA-cc**

**FELLER** 

A-2525 Günselsdorf, Austria

Telefon 0043-2256-62325-0

Fax: 0043-2256-62325-7

email: [sales@feller-at.com](mailto:sales@feller-at.com)

<http://www.feller-at.com>

**All dimensions in mm**

14.04.2015

lg 

**RoHS compliant**